

RP-75 Sealed EBW Detonator

P/N 188-7390

The RP-75 is a sealed EBW detonator with an integral connector for underwater use. All RP-75 detonators are individually tested to 1000 psi water pressure.

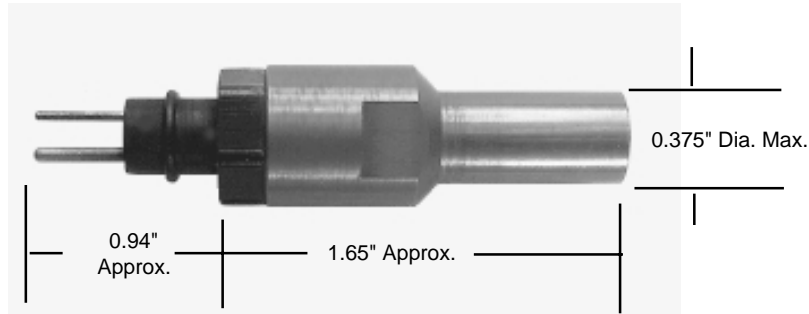

RP-75 Explosive Train

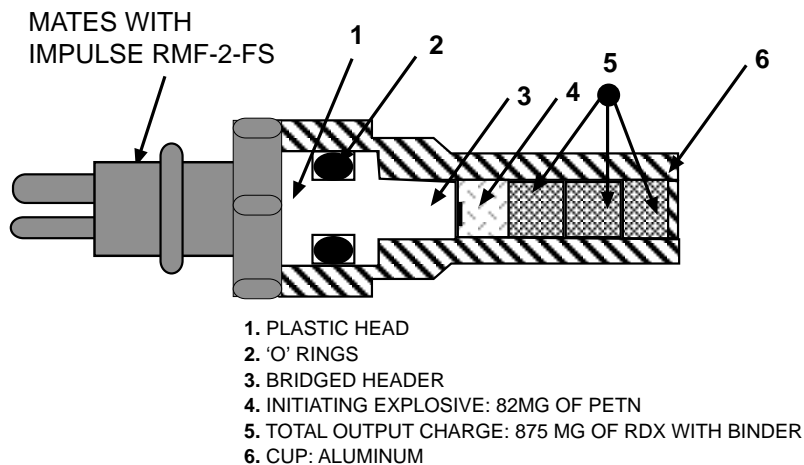

RP-75 Firing Parameters

- Threshold Burst Current: 180 amps
- Threshold Voltage: Approx. 500 volts
- Threshold Voltage Std. Deviation: 50 volts maximum
- Function Time: 7.5 μ sec. typical
- Function Time Simultaneity Standard Deviation: 0.125 μ sec Max.

Caution: While EBW and EFI Initiators are inherently less susceptible to accidental detonation during handling and set-up than devices containing primary explosives, electrical and electronic firing systems are sensitive to transient electrical energies which could cause premature triggering or firing. The blasting area must be clear of personnel and equipment before the detonator leads are connected to any RISI Firing System. Only approved RISI Firing Systems should ever be used to initiate or detonate any explosive product manufactured and authorized for sale by RISI.